

High Torque, Right Angle Slow Speed Agitator

Premium 316SS machined for greater corrosion resistance

Motors are 300 Series Stainless Steel

Dual, single-lip seals provide ultimate cleanability

Impeller shaft length available up to 144"



Jetfoil™ impeller technology provides 200% greater pumping rate over conventional axial blade impellers

The only *all* stainless steel, low speed, large capacity agitator

The robust Rotomaxx II, with right angle helical bevel gearbox, is designed for the most demanding operating environments and stringent CIP, washdown, pressure washing, and steam cleaning conditions.

The modular design allows for multiple shaft diameter, gear ratio, and motor horse power combinations with flex couplings between the motor/gearbox and gearbox/drive shaft to protect the gear drive from shock loads and dampen vibrations while isolating shaft bending moment and deflection loads from the torque loads on the gearbox.

The Admix Advantage

- ✓ Tank volumes to 60,000+ gallons
- ✓ Entire unit is designed for total wash-down duty for food, pharmaceutical and cosmetic industries
- ✓ Maintenance-free, greased-for-life, sealed bearings in bearing frame
- ✓ Premium high efficiency, ground helical bevel gearing provides 20-30% more efficient gearing than conventional worm gearing
- ✓ Synthetic food grade lubrication in gear drives
- ✓ Up to 15 HP Input
- ✓ Output torque up to 6100 in-lb with 1.25 service factor

Rotomaxx II Specifications

The Rotomaxx II series of stainless steel mixers are available in three (3) basic configurations as shown below:

Mixer Model	420 RMAX	620 RMAX	625 RMAX
Output Speed (RPM)	13 - 311	12 - 240	12 - 240
HP Range	1 - 7.5	1 - 10	1 - 15
Shaft Diameter	2"	2"	2.5"
Maximum Shaft Length	up to 130"	up to 130"	up to 144"
Impeller Diameter	up to 50"	up to 65"	up to 80"
Pumping Rate @ 1 cPs (GPM)	up to 24,000	up to 40,000	up to 56,000

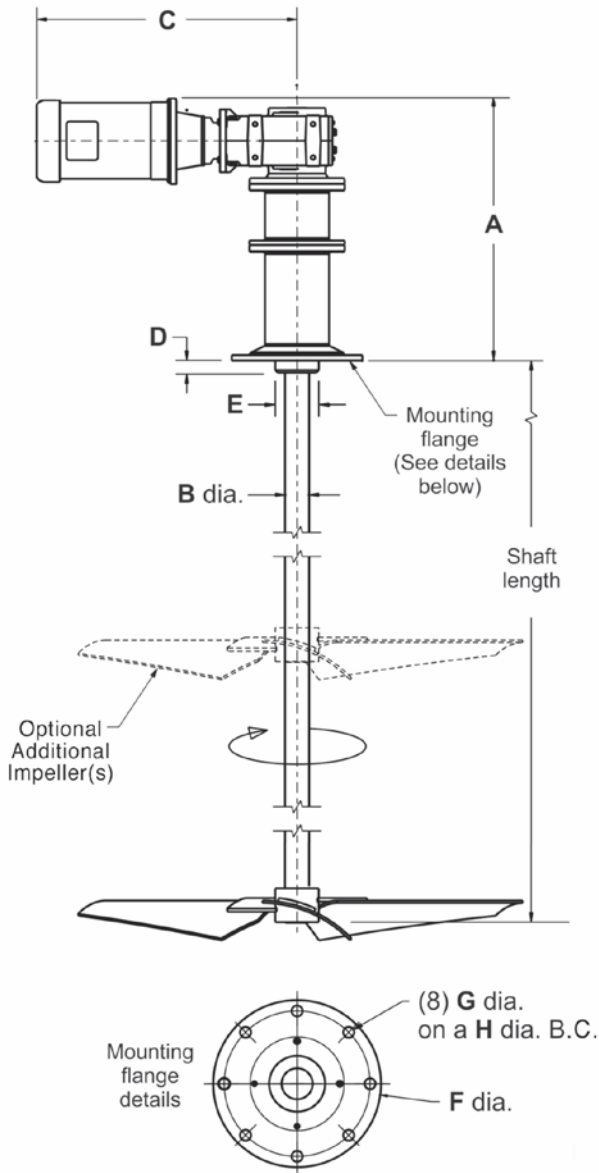

Features & Benefits

- ✓ Mounting for NEMA or IEC C-face/B5 Motors
- ✓ Flex couplings between the motor/gearbox and gearbox/drive shaft provide vibration damping and shock load protection to drive components.
- ✓ Three (3) waterproof pressure compensation vents allow air inside the gearbox and driveshaft bearing frame to expand and contract as temperatures inside and outside the agitator change and prevent moisture and contaminants from getting in.
- ✓ All non-rotating components are sealed with o-rings for greater protection
- ✓ Impeller shaft speeds from 12 to 311 RPM
- ✓ 2" to 2.50" diameter impeller shaft
- ✓ Impeller shaft available up to 144"
- ✓ 3-A compliant seal pedestals are available
- ✓ Permanent laser-marked nameplate

Rotomaxx II Dimensions

	420 RMAX	620 RMAX	625 RMAX
A	25.4	27.3	27.3
B	2.00	2.00	2.50
C	29	33	33
D	1.23	1.23	1.23
E	6.7	7.5	7.5
	6" - 150# ANSI	8" - 150# ANSI	8" - 150# ANSI
F	11.0	13.5	13.5
G	0.88	0.88	0.88
H	9.50	11.75	11.75

Dimensions are in inches

C & A may vary depending on motor horsepower



R-Cap Process Equipment, Inc. is an authorized sales representative of Admix, Inc.

R-Cap Process Equipment, Inc.

Website: www.r-cap.com

Email: rcap@r-cap.com

Main Office: 847.382.3003

Michigan Office: 248.977.5225

