

Easy All-in-One System – now with Programmable Logic Controller

The Admix Fastfeed PLC is an excellent solution for processors who want an all-in-one automated system for inducing and dispersing powder ingredients into mix tanks. With automation controls, your mix room benefits with greater efficiency and better operator ergonomics. The system also features an integrated liquid ring pump and high shear emulsifier that work together to ensure rapid incorporation and wetting out of powder ingredients.

Advantages of the Fastfeed PLC

- ✓ Fast and easy incorporation and dispersion of powder ingredients.
- ✓ No bending over or crouching down to check vacuum pressure or manually adjust valve levers.
- ✓ Built in safety features keep the system running in optimal condition and extend the life of the unit.
- ✓ Ability to save and easily access up to 500 recipes via the touchscreen monitor for quick reference before starting the job.
- ✓ Live data can be viewed during operation, such as the flow rate, vacuum pressure, temperature, and valve positioning.
- ✓ CIP procedures are initiated via the touchscreen.
- ✓ Ability to connect to the system remotely for maintenance or updates.



Now with
**Automation
Controls**
for even easier
operation!



Mechanical Features

- All contact surfaces are 316L with welds blended and polished
- Optional double mechanical seal for abrasive applications
- Optional wand for liquid additions

Automation Features

- Touchscreen operation
- Store 500 recipes
- Remote capability
- Better ergonomics
- One touch CIP mode
- Enhanced safety features
- Monitor live stats

An Overview of How the Fastfeed PLC Works

The Fastfeed PLC is designed to connect to your liquid source or recirculation tank. The operator uses the waist height table to add powder ingredients into the hopper (using your bag dump station or bulk delivery system is possible). Powder is pulled in and pumped through its high shear mixer/emulsifier called the Dynashear®. This results in instantaneous fluidization and shearing. Slurries with droplet and soft particle size reduction down to 4-5 microns are provided upon exiting the unit.

Uniform, Effective Flow of Powder

Traditional powder flow problems such as bridging or rat-holing are minimized due to a Liquid Ring Pump that creates constant vacuum within the flow stream, and being aided by a mechanical vibrator for more challenging ingredients. Powder suction is continuous even as viscosity and solids level increase, protecting the system against plugging. Powder feed rates are easily adjustable at the touchscreen to ensure that the proper concentration of dry materials are added quickly and effectively.

Complete 100% Dispersion of Powders

Ingredients are 100% dispersed as the powder slurry mixture passes through the integrated Dynashear® high shear mixer, where many applications are finished with just one pass through.

The table below illustrates typical powder feed rates.

Performance Table for Fastfeed

Ingredient	Powder Feed Rate (up to lbs/minute)	Typical Max. Concentration
Granulated (sugar/salt/phosphates)	200	70%
Dairy Powders (NFDM)	200	52%
Cocoa	90	35%
Soy	75	10%
Cook Starches	110	45%
Natural Gums (i.e. pectin)	30	6%
Carbomers	15	3.5%
Xanthan	15	3%

Model	Pump	Mixer	Hopper	Skid Fittings
FF-425-PLC	7.5 HP @ 1800 rpm	7.5 HP @ 3600 rpm	3.4 cubic ft	2" Ø TriClamp inlet 2" Ø TriClamp outlet

TriClamp® is a registered trademark of Tri-Clover\Alfa Laval

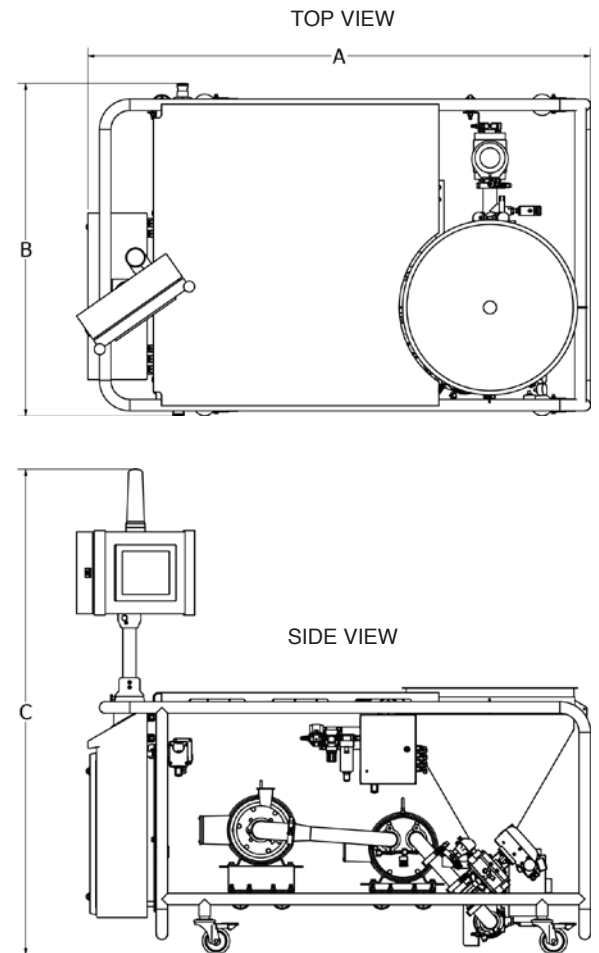

Model	A	B	C
FF-425-PLC	72.5"	48"	70"